

DATA SHEET

TSA6057; TSA6057T Radio tuning PLL frequency synthesizers

Product specification
Supersedes date of August 1988
File under Integrated Circuits, IC01

1997 Oct 29

Radio tuning PLL frequency synthesizers

TSA6057; TSA6057T

FEATURES

- On-chip AM and FM prescalers with high input sensitivity
- On-chip high performance one input (two output) tuning voltage amplifier for the AM and FM loop filters
- On-chip 2-level current amplifier (charge pump) to adjust the loop gain
- Only one reference oscillator (4 MHz) for both AM and FM
- High speed tuning due to a powerful digital memory phase detector
- 40 kHz output reference frequency for co-operation with the FM/IF system and microcomputer-based tuning interface IC (TEA6100)
- Oscillator frequency ranges of: 512 kHz to 30 MHz and 30 to 150 MHz
- 3 selectable reference frequencies of 1, 10 or 25 kHz for both tuning ranges
- Serial 2-wire I²C-bus interface to a microcontroller and one programmable address input
- Software controlled band switch output.



GENERAL DESCRIPTION

The TSA6057 is a bipolar single chip frequency synthesizer manufactured in SUBILO-N technology (components laterally separated by oxide). It performs all the tuning functions of a PLL radio tuning system. The IC is designed for application in all types of radio receivers.

ORDERING INFORMATION

TYPE NUMBER	PACKAGE		
	NAME	DESCRIPTION	VERSION
TSA6057	DIP16	plastic dual in-line package; 16 leads (300 mil); long body	SOT38-1
TSA6057T	SO16	plastic small outline package; 16 leads; body width 7.5 mm	SOT162-1

Radio tuning PLL frequency synthesizers

TSA6057; TSA6057T

QUICK REFERENCE DATA

SYMBOL	PARAMETER	CONDITIONS	MIN.	TYP.	MAX.	UNIT
V_{CC1}	supply voltage 1; pin 3		4.5	5.0	5.5	V
V_{CC2}	supply voltage 2; pin 16		V_{CC1}	8.5	12	V
I_{CC1}	supply current 1; pin 3	no outputs loaded	12	20	28	mA
I_{CC2}	supply current 2; pin 16	version C1	0.2	0.5	1	mA
		version C8	0.7	1	1.5	mA
$f_{iAM(max)}$	maximum input frequency on AM_I		30	–	–	MHz
$f_{iAM(min)}$	minimum input frequency on AM_I		–	–	0.512	MHz
$f_{iFM(max)}$	maximum input frequency on FM_I		150	–	–	MHz
$f_{iFM(min)}$	minimum input frequency on FM_I		–	–	30	MHz
$V_{iAM(rms)}$	input voltage on AM_I (RMS value)	$V_{iFM} = 0$ V	30	–	500	mV
$V_{iFM(rms)}$	input voltage on FM_I (RMS value)	$V_{iAM} = 0$ V	20	–	300	mV
P_{tot}	total power dissipation		–	0.14	–	W
T_{amb}	operating ambient temperature	version C1	–30	–	+85	°C
		version C8	–40	–	+85	°C

Radio tuning PLL frequency synthesizers

TSA6057; TSA6057T

BLOCK DIAGRAM

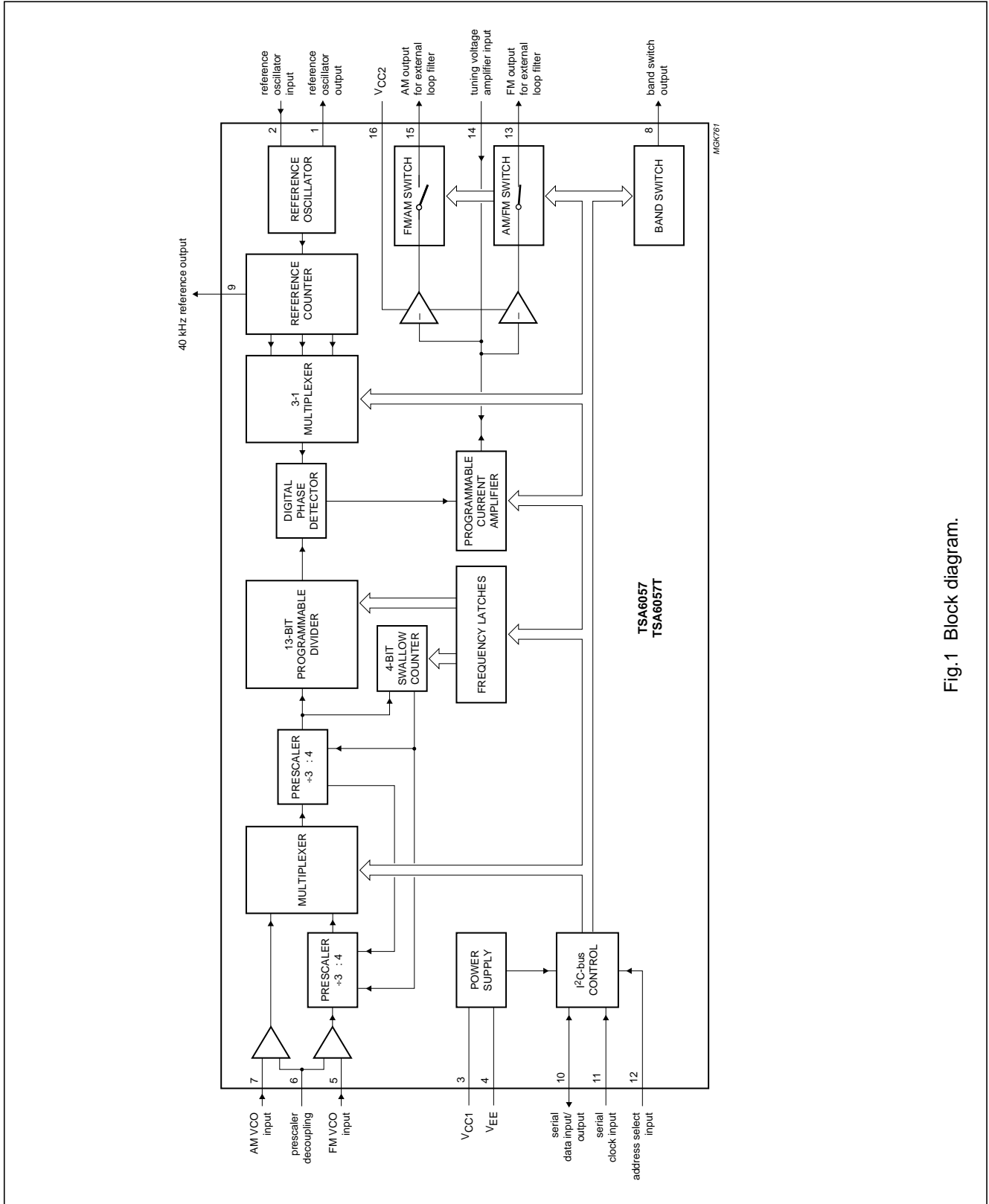

Fig.1 Block diagram.

Radio tuning PLL frequency synthesizers

TSA6057; TSA6057T

PINNING

SYMBOL	PIN	DESCRIPTION
XTAL1	1	reference oscillator output
XTAL2	2	reference oscillator input
V _{CC1}	3	positive supply voltage 1
V _{EE}	4	ground
FM _I	5	FM VCO input
DEC	6	prescaler decoupling
AM _I	7	AM VCO input
BS	8	band switch output
f _{ref}	9	40 kHz reference output
SDA	10	serial data input/output; I ² C-bus
SCL	11	serial clock input; I ² C-bus
AS	12	address select input; I ² C-bus
FM _O	13	FM output for external loop filter
LOOP _I	14	tuning voltage amplifier input
AM _O	15	AM output for external loop filter
V _{CC2}	16	positive supply voltage 2

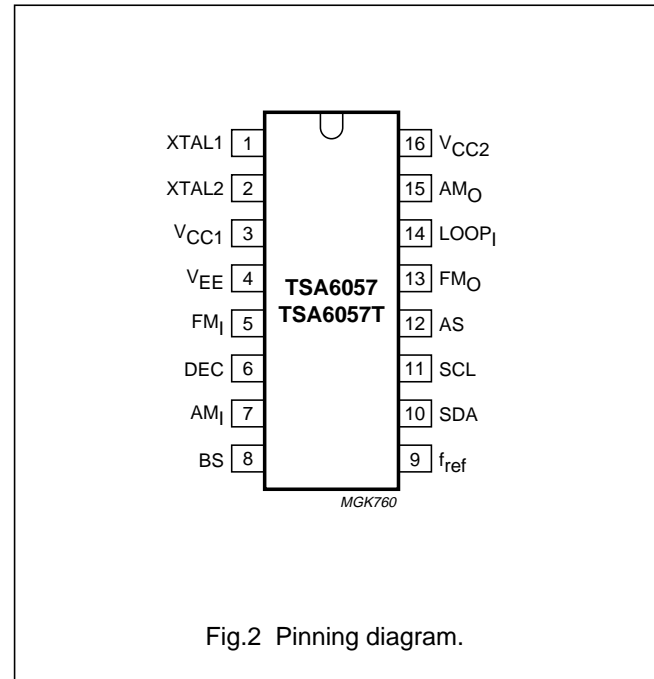

Fig.2 Pinning diagram.

FUNCTIONAL DESCRIPTION

The TSA6057 contains the following parts and facilities:

- Separate input amplifiers for the AM and FM VCO-signals.
- A prescaler with the divisors 3 : 4 on AM and 15 : 16 on FM, a multiplexer to select AM or FM and a 4-bit programmable swallow counter.
- A 13-bit programmable counter.
- A digital memory phase detector.
- A reference frequency channel comprised of a 4 MHz crystal oscillator followed by a reference counter. The reference frequency can be 1, 10 or 25 kHz and is applied to the digital memory phase detector. The reference counter also outputs a 40 kHz reference frequency to pin 9 for co-operation with the FM/IF system and microcomputer-based tuning interface IC (TEA6100).
- A programmable current amplifier (charge pump) which consists of a 5 and a 450 μ A current source. This allows adjustment of loop gain, thus providing high current-high speed tuning and low current-stable tuning.
- A one input, two output tuning voltage amplifier. One output is connected to the external AM loop filter and the other output to the external FM loop filter. Under software control, the AM output is switched to a high impedance state by the FM/AM switch in the FM position

and the FM output is switched to a high impedance state by the AM/FM switch in the AM position. The outputs can deliver a tuning voltage of up to 10.5 V.

- An I²C-bus interface with data latches and control logic. The I²C-bus is intended for communication between microcontrollers and different ICs or modules. Detailed information on the I²C-bus specification is available on request.
- A software-controlled band switch output.

Controls

The TSA6057 is controlled via the 2-wire I²C-bus. For programming there is one module address, a logic 0 R/W bit, a subaddress byte and four data bytes. The subaddress determines which one of the four data bytes is transmitted first. The module address contains a programmable address bit (D1) which with address select input AS (pin 12) makes it possible to operate two TSA6057s in one system.

The auto increment facility of the I²C-bus allows programming of the TSA6057 within one transmission (address + subaddress + 4 data bytes).

- The TSA6057 can also be partially programmed. Transmission must then be ended by a STOP condition.

The bit organization of the 4 data bytes is shown in Fig.3 and described in Tables 1 to 5.

Radio tuning PLL frequency synthesizers

TSA6057; TSA6057T

Table 1 The bits S0 to S16 (DB0: D1 to D7; DB1: D0 to D7 and DB2: D0 and D1) together with bit FM/AM (DB2: D5) are used to set the divisor of the input frequency at inputs AM_I (pin 7) or FM_I (pin 5). If the system is in lock the following is valid:

FM/AM	INPUT FREQUENCY (f _i)	INPUT
0	$(S0 \times 2^0 + S1 \times 2^1 + S13 \times 2^{13} + S14 \times 2^{14}) \times f_{ref}$	AM _I ⁽¹⁾
1	$(S0 \times 2^0 + S1 \times 2^1 + S15 \times 2^{15} + S16 \times 2^{16}) \times f_{ref}$	FM _I ⁽²⁾

Notes

1. The minimum dividing ratio for AM mode is 2⁶ = 64.
2. The minimum dividing ratio for FM mode is 2⁸ = 256.

Table 2 The bit CP is used to control the charge pump current (DB0: D0)

CP	CURRENT
0	low
1	high

Table 3 The bits REF1 and REF2 are used to set the reference frequency applied to the phase detector (DB2: D7 and D6)

REF1	REF2	FREQUENCY (kHz)
0	0	1
0	1	10
1	0	25
1	1	none

Table 4 The bit FM/AM OPAMP controls the switch AM/FM; FM/AM in the tuning voltage amplifier output circuitry (DB2: D4)

FM/AM OPAMP	SWITCH FM/AM	SWITCH AM/FM
1	closed	open
0	open	closed

Table 5 The bit BS controls the open collector band switch output (DB2: D2)

BS	BAND SWITCH OUTPUT
1	sink current
0	floating

Remark: data byte DB3 must be set to 0000 0000. It is also used for test purposes.

Radio tuning PLL frequency synthesizers

TSA6057; TSA6057T

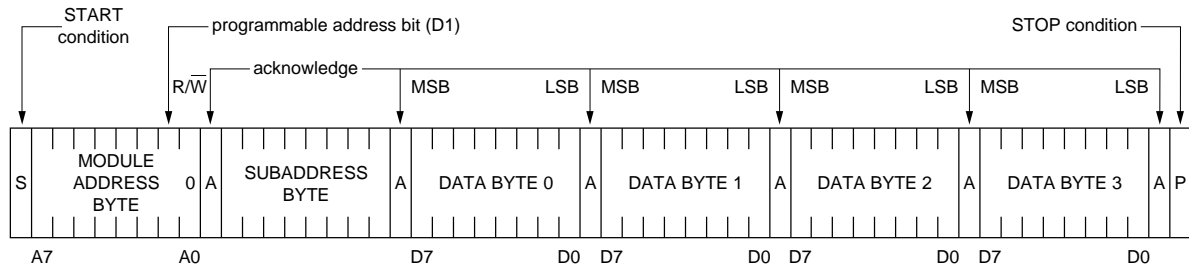

	MSB									LSB							
MODULE ADDRESS	1	1	0	0	0	1	0/1	0									
	A7									A0							
SUBADDRESS	0	0	0	0	0	0	0/1	0/1									
DATA BYTE 0 (DB0)	S6	S5	S4	S3	S2	S1	S0	CP									
	D7									D0							
DATA BYTE 1 (DB1)	S14	S13	S12	S11	S10	S9	S8	S7									
	D7									D0							
DATA BYTE 2 (DB2)	REF1	REF2	FM/AM	FM/AM	NOT USED	BS	S16	S15									
	D7									D0							
DATA BYTE 3 (DB3)	T1	T2	T3	NOT USED	NOT USED	NOT USED	NOT USED	NOT USED									
	D7									D0							

Examples using auto-increment facility

S	ADDRESS	A	SUBADDRESS 02	A	DB2	A	DB3	A	P
---	---------	---	---------------	---	-----	---	-----	---	---

S	ADDRESS	A	SUBADDRESS 00	A	DB0	A	DB1	A	P
---	---------	---	---------------	---	-----	---	-----	---	---

S	ADDRESS	A	SUBADDRESS 03	A	DB3	A	DB0	A	DB1	A	DB2	A	P
---	---------	---	---------------	---	-----	---	-----	---	-----	---	-----	---	---

MGK762

Fig.3 Bit organization.

Radio tuning PLL frequency synthesizers

TSA6057; TSA6057T

Sensitivity measurement

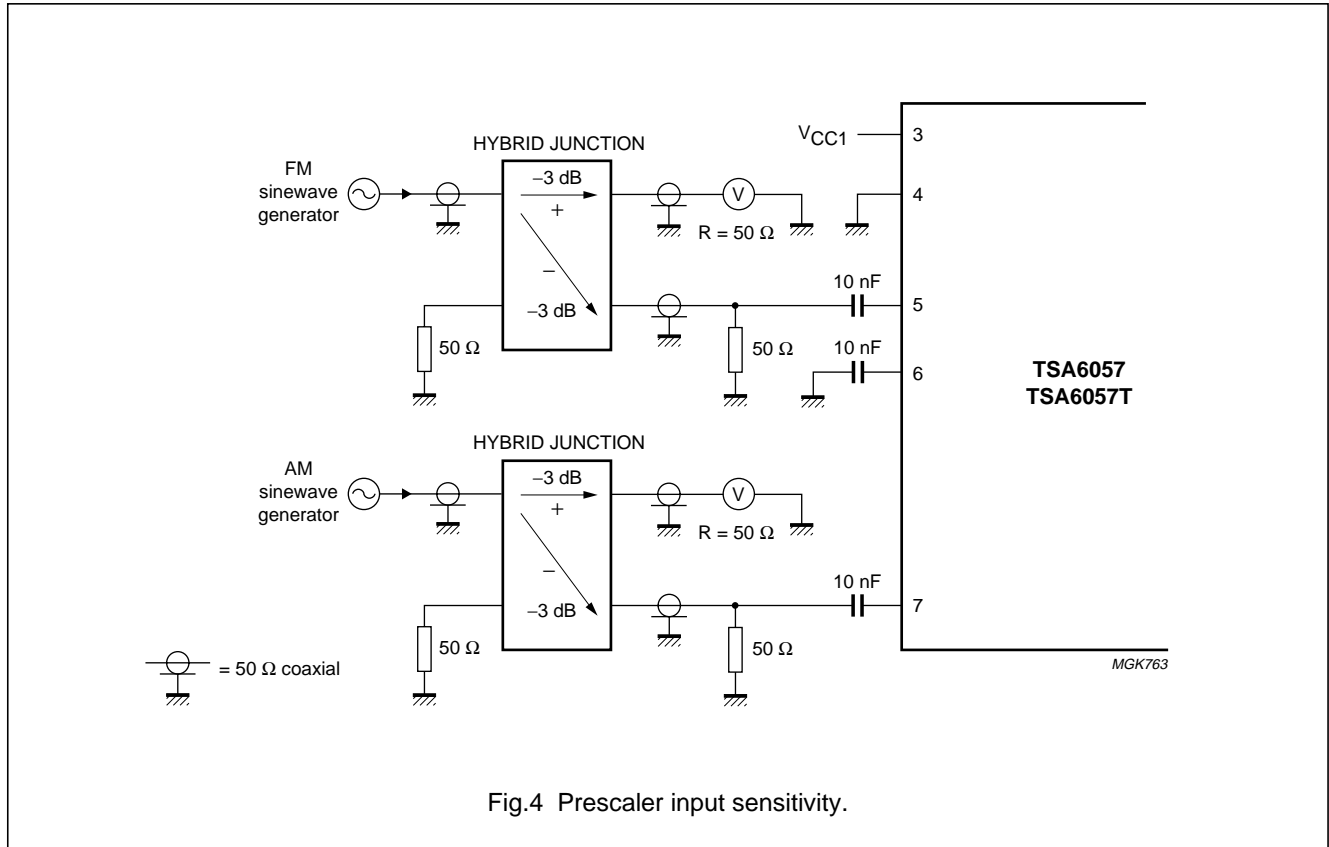

LIMITING VALUES

Limiting values in accordance with the Absolute Maximum System (IEC 134).

SYMBOL	PARAMETER	CONDITIONS	MIN.	MAX.	UNIT
V _{CC1}	supply voltage 1 (pin 3)		-0.3	+5.5	V
V _{CC2}	supply voltage 2 (pin 16)		V _{CC1}	12.5	V
P _{tot}	total power dissipation		-	0.85	W
T _{amb}	operating ambient temperature	version C1	-30	+85	°C
		version C8	-40	+85	°C
T _{stg}	storage temperature		-65	+150	°C

Radio tuning PLL frequency synthesizers

TSA6057; TSA6057T

CHARACTERISTICS

$V_{CC1} = 5\text{ V}$; $V_{CC2} = 8.5\text{ V}$; $T_{amb} = 25\text{ }^{\circ}\text{C}$; unless otherwise specified.

SYMBOL	PARAMETER	CONDITIONS	MIN.	TYP.	MAX.	UNIT
Supplies						
V_{CC1}	supply voltage 1 (pin 3)		4.5	5.0	5.5	V
V_{CC2}	supply voltage 2 (pin 16)	see Fig.6	V_{CC1}	8.5	12	V
I_{CC1}	supply current pin 3	no outputs loaded	12	20	28	mA
I_{CC2}	supply current pin 16	no outputs loaded version C1	0.7	1.0	1.5	mA
		version C8	0.2	0.5	1	mA
I²C-bus inputs (SDA and SCL)						
V_{IH}	input voltage HIGH		3.0	–	5.0	V
V_{IL}	input voltage LOW		–0.3	–	+1.5	V
I_{IH}	input current HIGH		–	–	10	μA
I_{IL}	input current LOW		–	–	10	μA
SDA output open-collector						
V_{OL}	output voltage LOW	$I_{OL} = 3.0\text{ mA}$	–	–	0.4	V
AS input						
V_{IH}	input voltage HIGH		3.0	–	5.0	V
V_{IL}	input voltage LOW		–0.3	–	+1.0	V
I_{IH}	input current HIGH		–	–	10	μA
I_{IL}	input current LOW		–	–	10	μA
RF inputs (AM_I and FM_I)						
$f_{iAM(max)}$	maximum input frequency on AM _I		30	–	–	MHz
$f_{iAM(min)}$	minimum input frequency on AM _I		–	–	0.512	MHz
$f_{iFM(max)}$	maximum input frequency on FM _I		150	–	–	MHz
$f_{iFM(min)}$	minimum input frequency on FM _I		–	–	30	MHz
PIN AM_I						
$V_{iAM(rms)}$	input voltage on AM _I (RMS value)	$V_{iFM} = 0\text{ V}$; measured in Fig.4	30	–	500	mV
R_{AM}	resistance		–	5.9	–	k Ω
C_{AM}	capacitance		–	2	–	pF
PIN FM_I						
$V_{iFM(rms)}$	input voltage on FM _I (RMS value)	$V_{iAM} = 0\text{ V}$; measured in Fig.4	20	–	300	mV
R_{FM}	resistance		–	3.6	–	k Ω
C_{FM}	capacitance		–	2	–	pF

Radio tuning PLL frequency synthesizers

TSA6057; TSA6057T

SYMBOL	PARAMETER	CONDITIONS	MIN.	TYP.	MAX.	UNIT
Oscillator (XTAL1 and XTAL2)						
R _{XTAL}	resistance	4 MHz crystal; see Fig.5	–	–	150	Ω
Programmable charge pump						
I _{chp}	output current to loop filter bit CP = logic 0	version C1	3	5	7	μA
	bit CP = logic 0	version C8	3	5	9	μA
	bit CP = logic 1		400	500	600	μA
Ripple rejection: f_{ripple} = 100 Hz						
RR1	20 log ΔV _{CC1} /ΔV _O		40	50	–	dB
RR2	20 log ΔV _{CC2} /ΔV _O		40	50	–	dB
Band switch output (pin 8)						
V _{OH}	output voltage HIGH		–	–	12	V
V _{OL}	output voltage LOW	I _{OL} = 3 mA	–	–	0.8	V
I _{LO}	output leakage current	V _{OH} = 12 V	–	–	10	μA
Reference frequency output (pin 9)						
f _{ref}	output frequency	4 MHz crystal	–	40	–	kHz
V _{OH}	output voltage HIGH	I _{source} = 5 μA	1.2	1.4	1.7	V
V _{OL}	output voltage LOW		–	0.1	0.2	V
Tuning voltage amplifier outputs						
AM OUTPUT (PIN 15)						
V _{O(max)}	maximum output voltage	I _{source} = 0.5 mA; version C1	V _{CC2} – 1.5	–	–	V
	maximum output voltage	I _{source} = 0.5 mA; version C8	V _{CC2} – 0.9	–	–	V
V _{O(min)}	minimum output voltage	I _{sink} = 1 mA	–	–	0.8	V
I _{source(max)}	maximum output source current		0.5	–	–	mA
I _{sink(max)}	maximum output sink current		1.0	–	–	mA
FM OUTPUT (PIN 13)						
V _{O(max)}	maximum output voltage	I _{source} = 0.5 mA; version C1	V _{CC2} – 1.5	–	–	V
	maximum output voltage	I _{source} = 0.5 mA; version C8	V _{CC2} – 0.9	–	–	V
V _{O(min)}	minimum output voltage	I _{sink} = 1 mA	–	–	0.8	V
I _{source}	maximum output source current		0.5	–	–	mA
I _{sink}	maximum output sink current		1.0	–	–	mA
Z _{O(off)}	impedance of switched off output		5	–	–	MΩ
I _{bias}	input bias current (absolute value)		–	1	5	nA

Radio tuning PLL frequency synthesizers

TSA6057; TSA6057T

APPLICATION INFORMATION

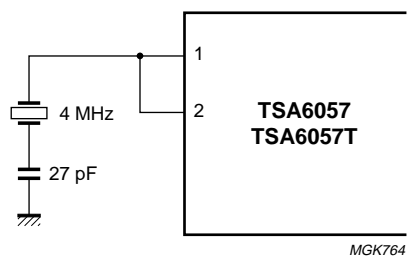
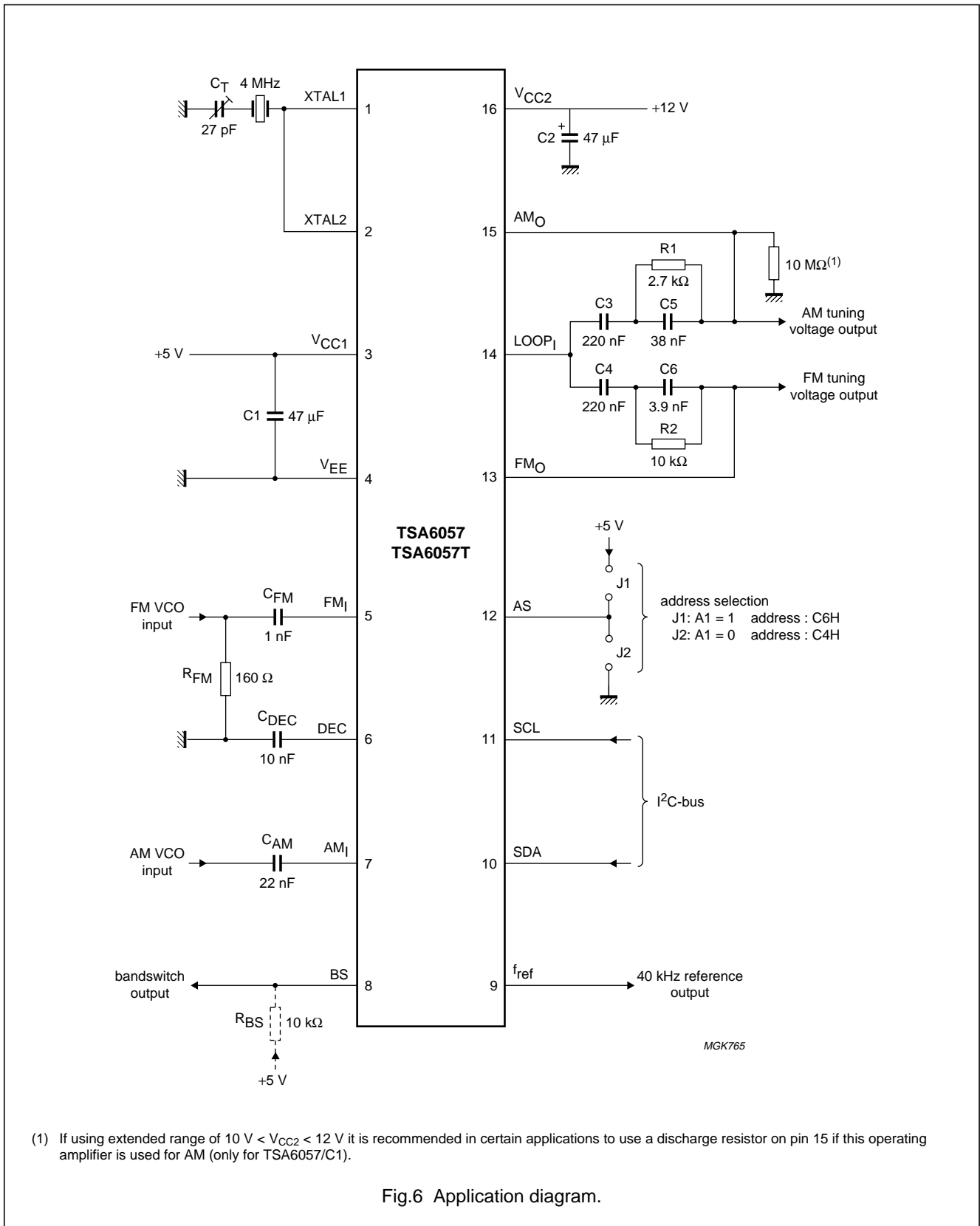

Fig.5 Crystal connection (4 MHz).

Radio tuning PLL frequency synthesizers

TSA6057; TSA6057T



(1) If using extended range of 10 V < V_{CC2} < 12 V it is recommended in certain applications to use a discharge resistor on pin 15 if this operating amplifier is used for AM (only for TSA6057/C1).

Fig.6 Application diagram.

Radio tuning PLL frequency synthesizers

TSA6057; TSA6057T

PACKAGE OUTLINES

DIP16: plastic dual in-line package; 16 leads (300 mil); long body

SOT38-1

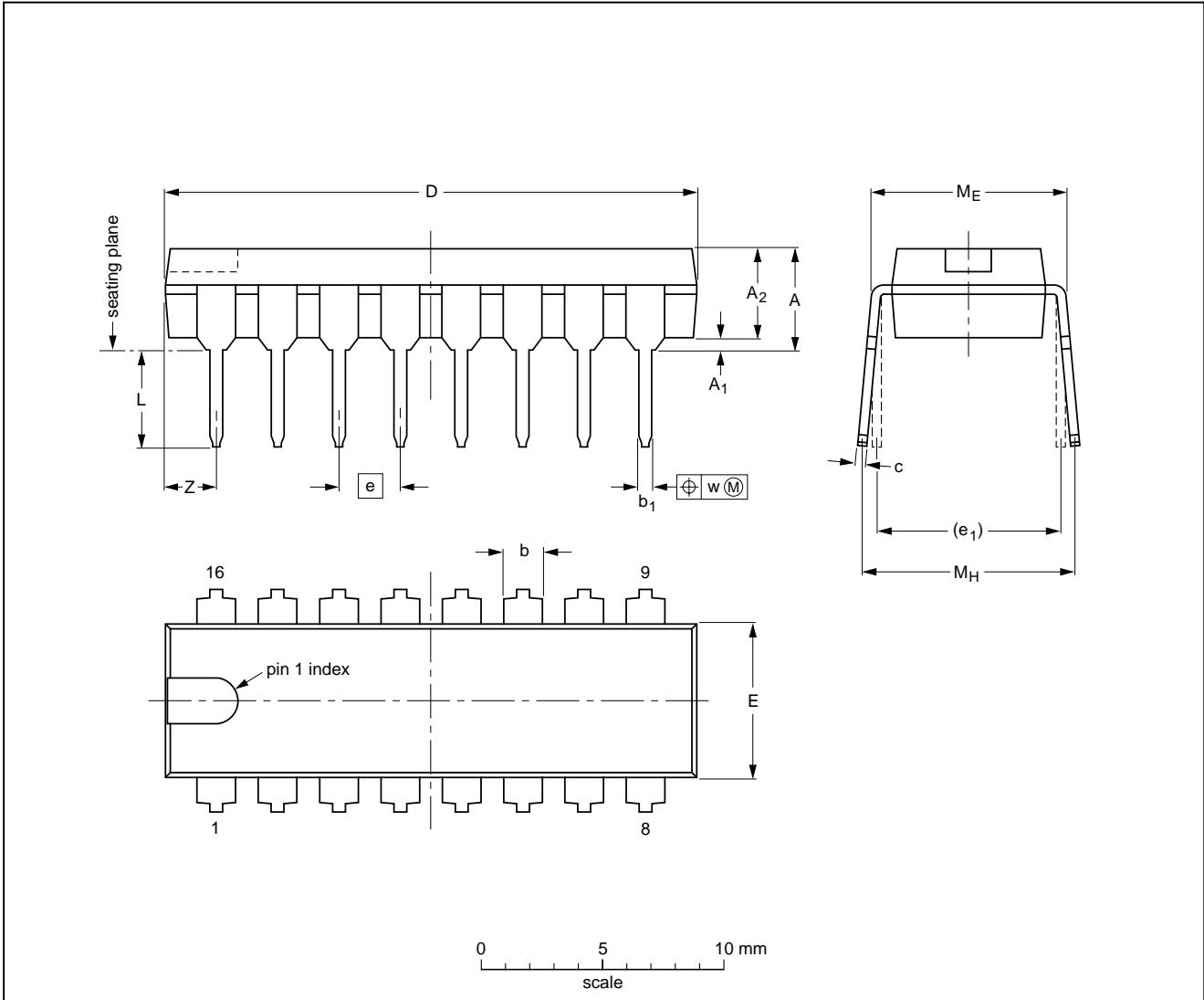

DIMENSIONS (inch dimensions are derived from the original mm dimensions)

UNIT	A max.	A ₁ min.	A ₂ max.	b	b ₁	c	D ⁽¹⁾	E ⁽¹⁾	e	e ₁	L	M _E	M _H	w	Z ⁽¹⁾ max.
mm	4.7	0.51	3.7	1.40 1.14	0.53 0.38	0.32 0.23	21.8 21.4	6.48 6.20	2.54	7.62	3.9 3.4	8.25 7.80	9.5 8.3	0.254	2.2
inches	0.19	0.020	0.15	0.055 0.045	0.021 0.015	0.013 0.009	0.86 0.84	0.26 0.24	0.10	0.30	0.15 0.13	0.32 0.31	0.37 0.33	0.01	0.087

Note

1. Plastic or metal protrusions of 0.25 mm maximum per side are not included.

OUTLINE VERSION	REFERENCES				EUROPEAN PROJECTION	ISSUE DATE
	IEC	JEDEC	EIAJ			
SOT38-1	050G09	MO-001AE				92-10-02 95-01-19

Radio tuning PLL frequency synthesizers

TSA6057; TSA6057T

SO16: plastic small outline package; 16 leads; body width 7.5 mm

SOT162-1

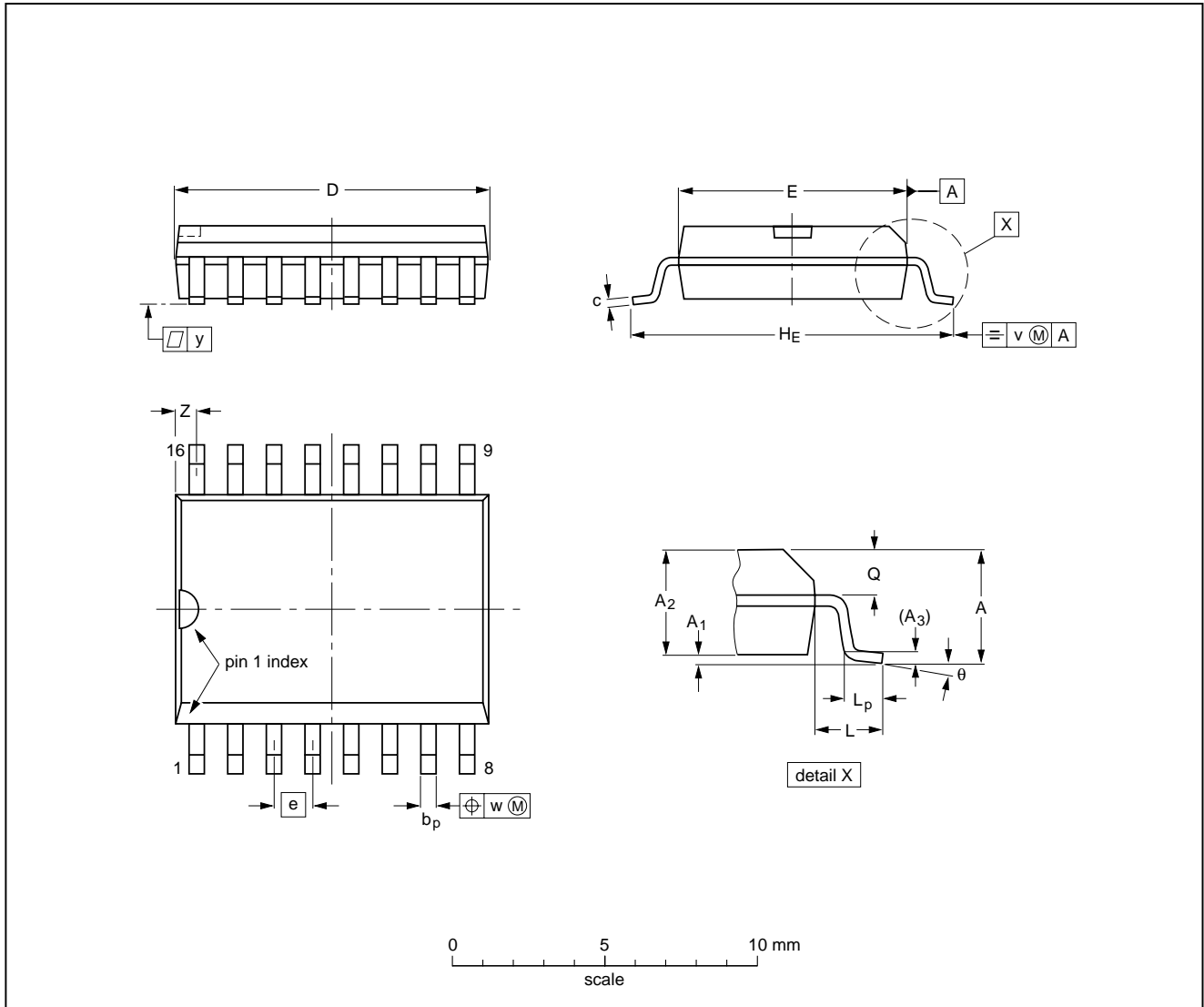

DIMENSIONS (inch dimensions are derived from the original mm dimensions)

UNIT	A max.	A ₁	A ₂	A ₃	b _p	c	D ⁽¹⁾	E ⁽¹⁾	e	H _E	L	L _p	Q	v	w	y	z ⁽¹⁾	θ
mm	2.65	0.30 0.10	2.45 2.25	0.25	0.49 0.36	0.32 0.23	10.5 10.1	7.6 7.4	1.27	10.65 10.00	1.4	1.1 0.4	1.1 1.0	0.25	0.25	0.1	0.9 0.4	8° 0°
inches	0.10	0.012 0.004	0.096 0.089	0.01	0.019 0.014	0.013 0.009	0.41 0.40	0.30 0.29	0.050	0.419 0.394	0.055	0.043 0.016	0.043 0.039	0.01	0.01	0.004	0.035 0.016	

Note

1. Plastic or metal protrusions of 0.15 mm maximum per side are not included.

OUTLINE VERSION	REFERENCES				EUROPEAN PROJECTION	ISSUE DATE
	IEC	JEDEC	EIAJ			
SOT162-1	075E03	MS-013AA				95-01-24 97-05-22

Radio tuning PLL frequency synthesizers

TSA6057; TSA6057T

SOLDERING

Introduction

There is no soldering method that is ideal for all IC packages. Wave soldering is often preferred when through-hole and surface mounted components are mixed on one printed-circuit board. However, wave soldering is not always suitable for surface mounted ICs, or for printed-circuits with high population densities. In these situations reflow soldering is often used.

This text gives a very brief insight to a complex technology. A more in-depth account of soldering ICs can be found in our "IC Package Databook" (order code 9398 652 90011).

DIP

SOLDERING BY DIPPING OR BY WAVE

The maximum permissible temperature of the solder is 260 °C; solder at this temperature must not be in contact with the joint for more than 5 seconds. The total contact time of successive solder waves must not exceed 5 seconds.

The device may be mounted up to the seating plane, but the temperature of the plastic body must not exceed the specified maximum storage temperature ($T_{stg\ max}$). If the printed-circuit board has been pre-heated, forced cooling may be necessary immediately after soldering to keep the temperature within the permissible limit.

REPAIRING SOLDERED JOINTS

Apply a low voltage soldering iron (less than 24 V) to the lead(s) of the package, below the seating plane or not more than 2 mm above it. If the temperature of the soldering iron bit is less than 300 °C it may remain in contact for up to 10 seconds. If the bit temperature is between 300 and 400 °C, contact may be up to 5 seconds.

SO

REFLOW SOLDERING

Reflow soldering techniques are suitable for all SO packages.

Reflow soldering requires solder paste (a suspension of fine solder particles, flux and binding agent) to be applied to the printed-circuit board by screen printing, stencilling or pressure-syringe dispensing before package placement.

Several techniques exist for reflowing; for example, thermal conduction by heated belt. Dwell times vary between 50 and 300 seconds depending on heating method. Typical reflow temperatures range from 215 to 250 °C.

Preheating is necessary to dry the paste and evaporate the binding agent. Preheating duration: 45 minutes at 45 °C.

WAVE SOLDERING

Wave soldering techniques can be used for all SO packages if the following conditions are observed:

- A double-wave (a turbulent wave with high upward pressure followed by a smooth laminar wave) soldering technique should be used.
- The longitudinal axis of the package footprint must be parallel to the solder flow.
- The package footprint must incorporate solder thieves at the downstream end.

During placement and before soldering, the package must be fixed with a droplet of adhesive. The adhesive can be applied by screen printing, pin transfer or syringe dispensing. The package can be soldered after the adhesive is cured.

Maximum permissible solder temperature is 260 °C, and maximum duration of package immersion in solder is 10 seconds, if cooled to less than 150 °C within 6 seconds. Typical dwell time is 4 seconds at 250 °C.

A mildly-activated flux will eliminate the need for removal of corrosive residues in most applications.

REPAIRING SOLDERED JOINTS

Fix the component by first soldering two diagonally-opposite end leads. Use only a low voltage soldering iron (less than 24 V) applied to the flat part of the lead. Contact time must be limited to 10 seconds at up to 300 °C. When using a dedicated tool, all other leads can be soldered in one operation within 2 to 5 seconds between 270 and 320 °C.

Radio tuning PLL frequency synthesizers

TSA6057; TSA6057T

DEFINITIONS

Data sheet status	
Objective specification	This data sheet contains target or goal specifications for product development.
Preliminary specification	This data sheet contains preliminary data; supplementary data may be published later.
Product specification	This data sheet contains final product specifications.
Limiting values	
Limiting values given are in accordance with the Absolute Maximum Rating System (IEC 134). Stress above one or more of the limiting values may cause permanent damage to the device. These are stress ratings only and operation of the device at these or at any other conditions above those given in the Characteristics sections of the specification is not implied. Exposure to limiting values for extended periods may affect device reliability.	
Application information	
Where application information is given, it is advisory and does not form part of the specification.	

LIFE SUPPORT APPLICATIONS

These products are not designed for use in life support appliances, devices, or systems where malfunction of these products can reasonably be expected to result in personal injury. Philips customers using or selling these products for use in such applications do so at their own risk and agree to fully indemnify Philips for any damages resulting from such improper use or sale.

PURCHASE OF PHILIPS I²C COMPONENTS

Purchase of Philips I²C components conveys a license under the Philips' I²C patent to use the components in the I²C system provided the system conforms to the I²C specification defined by Philips. This specification can be ordered using the code 9398 393 40011.

Radio tuning PLL frequency synthesizers

TSA6057; TSA6057T

NOTES

Radio tuning PLL frequency synthesizers

TSA6057; TSA6057T

NOTES

Radio tuning PLL frequency synthesizers

TSA6057; TSA6057T

NOTES

Philips Semiconductors – a worldwide company

Argentina: see South America

Australia: 34 Waterloo Road, NORTH RYDE, NSW 2113,
Tel. +61 2 9805 4455, Fax. +61 2 9805 4466

Austria: Computerstr. 6, A-1101 WIEN, P.O. Box 213, Tel. +43 160 1010,
Fax. +43 160 101 1210

Belarus: Hotel Minsk Business Center, Bld. 3, r. 1211, Volodarski Str. 6,
220050 MINSK, Tel. +375 172 200 733, Fax. +375 172 200 773

Belgium: see The Netherlands

Brazil: see South America

Bulgaria: Philips Bulgaria Ltd., Energoproject, 15th floor,
51 James Bourchier Blvd., 1407 SOFIA,
Tel. +359 2 689 211, Fax. +359 2 689 102

Canada: PHILIPS SEMICONDUCTORS/COMPONENTS,
Tel. +1 800 234 7381

China/Hong Kong: 501 Hong Kong Industrial Technology Centre,
72 Tat Chee Avenue, Kowloon Tong, HONG KONG,
Tel. +852 2319 7888, Fax. +852 2319 7700

Colombia: see South America

Czech Republic: see Austria

Denmark: Prags Boulevard 80, PB 1919, DK-2300 COPENHAGEN S,
Tel. +45 32 88 2636, Fax. +45 31 57 0044

Finland: Sinikalliontie 3, FIN-02630 ESPOO,
Tel. +358 9 615800, Fax. +358 9 61580920

France: 4 Rue du Port-aux-Vins, BP317, 92156 SURESNES Cedex,
Tel. +33 1 40 99 6161, Fax. +33 1 40 99 6427

Germany: Hammerbrookstraße 69, D-20097 HAMBURG,
Tel. +49 40 23 53 60, Fax. +49 40 23 536 300

Greece: No. 15, 25th March Street, GR 17778 TAVROS/ATHENS,
Tel. +30 1 4894 339/239, Fax. +30 1 4814 240

Hungary: see Austria

India: Philips INDIA Ltd, Band Box Building, 2nd floor,
254-D, Dr. Annie Besant Road, Worli, MUMBAI 400 025,
Tel. +91 22 493 8541, Fax. +91 22 493 0966

Indonesia: see Singapore

Ireland: Newstead, Clonskeagh, DUBLIN 14,
Tel. +353 1 7640 000, Fax. +353 1 7640 200

Israel: RAPAC Electronics, 7 Kehilat Saloniki St, PO Box 18053,
TEL AVIV 61180, Tel. +972 3 645 0444, Fax. +972 3 649 1007

Italy: PHILIPS SEMICONDUCTORS, Piazza IV Novembre 3,
20124 MILANO, Tel. +39 2 6752 2531, Fax. +39 2 6752 2557

Japan: Philips Bldg 13-37, Kohnan 2-chome, Minato-ku, TOKYO 108,
Tel. +81 3 3740 5130, Fax. +81 3 3740 5077

Korea: Philips House, 260-199 Itaewon-dong, Yongsan-ku, SEOUL,
Tel. +82 2 709 1412, Fax. +82 2 709 1415

Malaysia: No. 76 Jalan Universiti, 46200 PETALING JAYA, SELANGOR,
Tel. +60 3 750 5214, Fax. +60 3 757 4880

Mexico: 5900 Gateway East, Suite 200, EL PASO, TEXAS 79905,
Tel. +9-5 800 234 7381

Middle East: see Italy

Netherlands: Postbus 90050, 5600 PB EINDHOVEN, Bldg. VB,
Tel. +31 40 27 82785, Fax. +31 40 27 88399

New Zealand: 2 Wagener Place, C.P.O. Box 1041, AUCKLAND,
Tel. +64 9 849 4160, Fax. +64 9 849 7811

Norway: Box 1, Manglerud 0612, OSLO,
Tel. +47 22 74 8000, Fax. +47 22 74 8341

Philippines: Philips Semiconductors Philippines Inc.,
106 Valero St. Salcedo Village, P.O. Box 2108 MCC, MAKATI,
Metro MANILA, Tel. +63 2 816 6380, Fax. +63 2 817 3474

Poland: Ul. Lukiska 10, PL 04-123 WARSZAWA,
Tel. +48 22 612 2831, Fax. +48 22 612 2327

Portugal: see Spain

Romania: see Italy

Russia: Philips Russia, Ul. Usatcheva 35A, 119048 MOSCOW,
Tel. +7 095 755 6918, Fax. +7 095 755 6919

Singapore: Lorong 1, Toa Payoh, SINGAPORE 1231,
Tel. +65 350 2538, Fax. +65 251 6500

Slovakia: see Austria

Slovenia: see Italy

South Africa: S.A. PHILIPS Pty Ltd., 195-215 Main Road Martindale,
2092 JOHANNESBURG, P.O. Box 7430 Johannesburg 2000,
Tel. +27 11 470 5911, Fax. +27 11 470 5494

South America: Rua do Rocio 220, 5th floor, Suite 51,
04552-903 São Paulo, SÃO PAULO - SP, Brazil,
Tel. +55 11 821 2333, Fax. +55 11 829 1849

Spain: Balmes 22, 08007 BARCELONA,
Tel. +34 3 301 6312, Fax. +34 3 301 4107

Sweden: Kottbygatan 7, Akalla, S-16485 STOCKHOLM,
Tel. +46 8 632 2000, Fax. +46 8 632 2745

Switzerland: Allmendstrasse 140, CH-8027 ZÜRICH,
Tel. +41 1 488 2686, Fax. +41 1 481 7730

Taiwan: Philips Semiconductors, 6F, No. 96, Chien Kuo N. Rd., Sec. 1,
TAIPEI, Taiwan Tel. +886 2 2134 2865, Fax. +886 2 2134 2874

Thailand: PHILIPS ELECTRONICS (THAILAND) Ltd.,
209/2 Sanpavuth-Bangna Road Prakanong, BANGKOK 10260,
Tel. +66 2 745 4090, Fax. +66 2 398 0793

Turkey: Talatpasa Cad. No. 5, 80640 GÜLTEPE/ISTANBUL,
Tel. +90 212 279 2770, Fax. +90 212 282 6707

Ukraine: PHILIPS UKRAINE, 4 Patrice Lumumba str., Building B, Floor 7,
252042 KIEV, Tel. +380 44 264 2776, Fax. +380 44 268 0461

United Kingdom: Philips Semiconductors Ltd., 276 Bath Road, Hayes,
MIDDLESEX UB3 5BX, Tel. +44 181 730 5000, Fax. +44 181 754 8421

United States: 811 East Arques Avenue, SUNNYVALE, CA 94088-3409,
Tel. +1 800 234 7381

Uruguay: see South America

Vietnam: see Singapore

Yugoslavia: PHILIPS, Trg N. Pasica 5/v, 11000 BEOGRAD,
Tel. +381 11 625 344, Fax. +381 11 635 777

For all other countries apply to: Philips Semiconductors, Marketing & Sales Communications,
Building BE-p, P.O. Box 218, 5600 MD EINDHOVEN, The Netherlands, Fax. +31 40 27 24825

Internet: <http://www.semiconductors.philips.com>

© Philips Electronics N.V. 1997

SCA55

All rights are reserved. Reproduction in whole or in part is prohibited without the prior written consent of the copyright owner.

The information presented in this document does not form part of any quotation or contract, is believed to be accurate and reliable and may be changed without notice. No liability will be accepted by the publisher for any consequence of its use. Publication thereof does not convey nor imply any license under patent- or other industrial or intellectual property rights.

Printed in The Netherlands

547027/1200/03/pp20

Date of release: 1997 Oct 29

Document order number: 9397 750 02748

Let's make things better.

**Philips
Semiconductors**



PHILIPS